

# RS 422 / RS 485 Fieldbus Isolating Repeater

## DIN-Rail Model D1061S

### Characteristics:

#### General Description:

The single channel DIN-Rail RS 422 / RS 485 Fieldbus Isolating Repeater D1061S is used to separate Intrinsically Safe RS 422 / RS 485 equipment located in Hazardous Area from a RS 232 / RS 422 / RS 485 controller located in Safe Area.

Transmission speed is dip-switch adjustable from 1.2 Kbit/s up to 1.5 Mbit/s. Terminating impedance is dip-switch selectable inside the unit (250 Ω value) for both sides of communication lines (Hazardous Area and Safe Area side). RS422 / RS 485 connection in Safe Area is provided both on terminal block and DB9 female connector on the unit.

RS232 connection is provided on DB9 female connector.

The module also provides a shield terminal block for connecting cable on Hazardous Area side.

#### Function:

1 channel I.S. RS 422 / RS 485 isolating repeater, provides 3 port isolation (input/output/supply).

#### Signalling LEDs:

Power supply indication (green), Rx-Tx transmission (yellow).

#### Field Configurability:

Hardware is totally configurable via dip-switches; parameters are:

Transmission speed adjustable from 1.2 Kbit/s up to 1.5 Mbit/s.

Terminating impedance enabled or disabled in both communication lines.

RS422 / RS 485 connection selection from Terminal Block or DB9 female connector.

#### EMC:

Fully compliant with CE marking applicable requirements.

### Front Panel and Features:

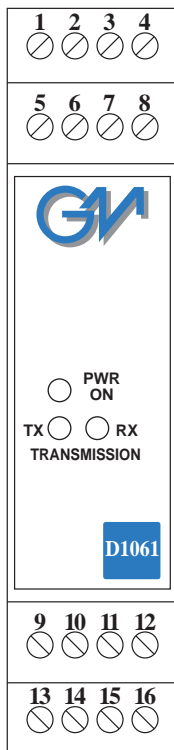

- RS 422 / RS 485 Hazardous Area I.S. Signal.
- RS 232 / RS 422 / RS 485 Safe Area Signal.
- Transmission speed up to 1.5 Mbit/s.
- DIP-Switch Field programmability.
- Installation in Zone 2, Div. 2.
- Three port isolation, Input/Output/Supply.
- EMC Compatibility to EN61000-6-2, EN61000-6-4.
- ATEX, FM & FM-C, Russia and Ukraine Certifications.
- DNV Type Approval Certificate No. A-10169 for marine applications.
- High Reliability, SMD components.
- Simplified installation using standard DIN Rail with plug-in terminal blocks.
- 250 Vrms (Um) max. voltage applied to the instruments associated with barrier.

### Ordering Information:

<b>Model:</b>	<b>D1061S</b>	
Power Bus enclosure		/B

### Technical Data:

#### Supply:

24 V nom (20 to 30 V) reverse polarity protected ripple within voltage limits  $\leq 5$  Vpp.

**Current consumption @ 24 V:** 100 mA.

**Max. power consumption:** 2.80 W with 30 V supply voltage.

#### Isolation (Test Voltage):

I.S. RS422-RS485 / RS232-RS422-RS485 1.5 KV;

I.S. RS422-RS485 / Supply 1.5 KV;

RS232-RS422-RS485 / Supply 500 V.

#### Input/Output I.S. Hazardous Area:

RS 422 / RS 485 Intrinsically Safe connection

(EIA RS-422-A and EIA RS-485 applicable standard).

**Terminating impedance:** 250 Ω dip-switch selectable.

**Transmission speed:** 1.2, 2.4, 4.8, 9.6, 14.4, 19.2, 38.4, 57.6, 93.75, 115.2, 187.5, 375, 500, 750 Kbit/s or 1.0, 1.5 Mbit/s dip-switch configurable.

**Transmission cable length:**  $\leq 1200$  m up to 93.75 Kbit/s,  $\leq 1000$  m up to 187.5 Kbit/s,  $\leq 400$  m up to 500 Kbit/s,  $\leq 200$  m up to 1.5 Mbit/s.

**Connection:** terminal block up to 2.5 mm<sup>2</sup>, shield terminal block provided for cable connection.

#### Output/Input Safe Area:

RS232 / RS 422 / RS 485 connection

(EIA RS-232-C, EIA RS-422-A and EIA RS-485 applicable standard).

**RS 422 / RS 485 Terminating impedance:** 250 Ω dip-switch selectable.

**RS 422 / RS 485 Transmission speed:** see above.

**RS 422 / RS 485 Transmission cable length:** see above.

**RS 422 / RS 485 Connection:** terminal block up to 2.5 mm<sup>2</sup> or DB9 female connector (requires DB9 male mating connector), dip switch configurable.

**RS 232 Transmission speed:** 1.2, 2.4, 4.8, 9.6, 14.4, 19.2, 38.4, 57.6, 93.75, 115.2 Kbit/s dip-switch configurable.

**RS 232 Connection:** DB9 female connector (requires DB9 male mating connector).

#### Compatibility:

**CE** CE mark compliant, conforms to 94/9/EC Atex Directive and to 89/336/CEE EMC Directive.

#### Environmental conditions:

**Operating:** Temperature limits -20 to + 60 °C, relative humidity max 90 % non condensing, up to 35 °C.

**Storage:** Temperature limits - 40 to + 80 °C.

#### Safety Description:

**Ex** II (1) G D [EEx ia] IIC, I M2 [EEx ia] I, II 3 G EEx nA IIC T4 associated electrical apparatus.

Uo/Voc = 3.7 V, Io/Isc = 225 mA, Po/Po = 206 mW at terminals 13-14 and 15-16.

Ui/Vmax = 30 V, Ii/Imax = 282 mA, Ci = 0 nF, Li = 0 μH at terminals 13-14-15-16.

Um = 250 Vrms, -20 °C ≤ Ta ≤ 60°C.

**Approvals:** DNV-2004-OSL-ATEX-0199 conforms to EN50014, EN50020, FM & FM-C No. 3024644, 3024644C, conforms to Class 3600, 3610, 3611, 3810 and C22.2 No.142, C22.2 No.157, C22.2 No.213, E60079-0, E60079-11, E60079-15, TCCEXEE (Russia) Nr.665 according to GOST R 51330.0-99, 51330.10-99 [Exia] IIC X, TCCEXEE (Ukraine) Nr.665 according to GOST 12.2.007.0, 22782.0, 22782.5 Exia IIC X, Gosgortekhnadzor of Russia Permit Nr. PPC 04-11284. DNV Type Approval Certificate No. A-10169 for marine applications.

#### Mounting:

T35 DIN Rail according to EN50022.

**Weight:** about 160 g.

**Connection:** By polarized plug-in disconnect screw terminal blocks to accommodate terminations up to 2.5 mm<sup>2</sup> and SUB D 9 poles (DB9) DIN 41652 female connector (only for RS 232, RS 422, RS 485 Safe Area connection).

**Location:** Safe Area/Non Hazardous Locations or Zone 2, Group IIC T4, Class I, Division 2, Groups A, B, C, D Temperature Code T4 and Class I, Zone 2, Group IIC, IIB, IIA T4 installation.

**Protection class:** IP 20.

**Dimensions:** Width 22.5 mm, Depth 99 mm, Height 114.5 mm.

## Parameters Table:

Safety Description	Maximum External Parameters			
	Group Cenelec	Co/Ca (μF)	Lo/La (mH)	Lo/Ro (μH/Ω)
<b>Terminals 13-14 and 15-16</b> Uo/Voc = 3.7 V Io/Isc = 225 mA Po/Po = 206 mW	II C	100	0.7	173
	II B	1000	2.8	693
	II A	1000	5.6	1386
<b>Terminals 13-14-15-16</b> Ui/Vmax = 30 V Ii/Imax = 282 mA Ci = 0 nF; Li = 0 μH				



## Function Diagram:

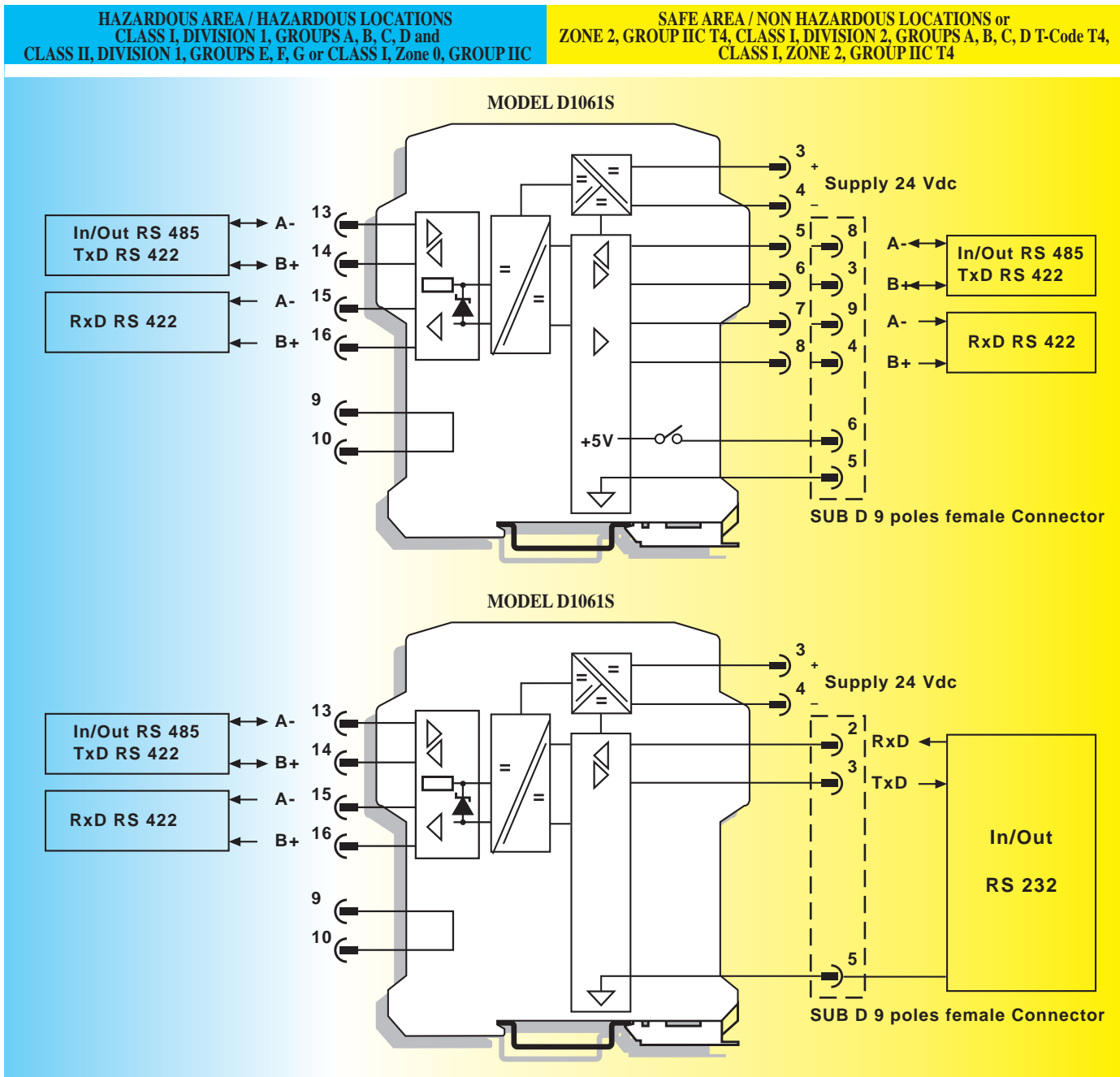

**Function Diagram:**

**HAZARDOUS AREA / HAZARDOUS LOCATIONS**  
 CLASS I, DIVISION 1, GROUPS A, B, C, D and  
 CLASS II, DIVISION 1, GROUPS E, F, G or CLASS I, Zone 0, GROUP IIC

**SAFE AREA / NON HAZARDOUS LOCATIONS or**  
 ZONE 2, GROUP IIC T4, CLASS I, DIVISION 2, GROUPS A, B, C, D T-Code T4,  
 CLASS I, ZONE 2, GROUP IIC T4

**MODEL D1061S**

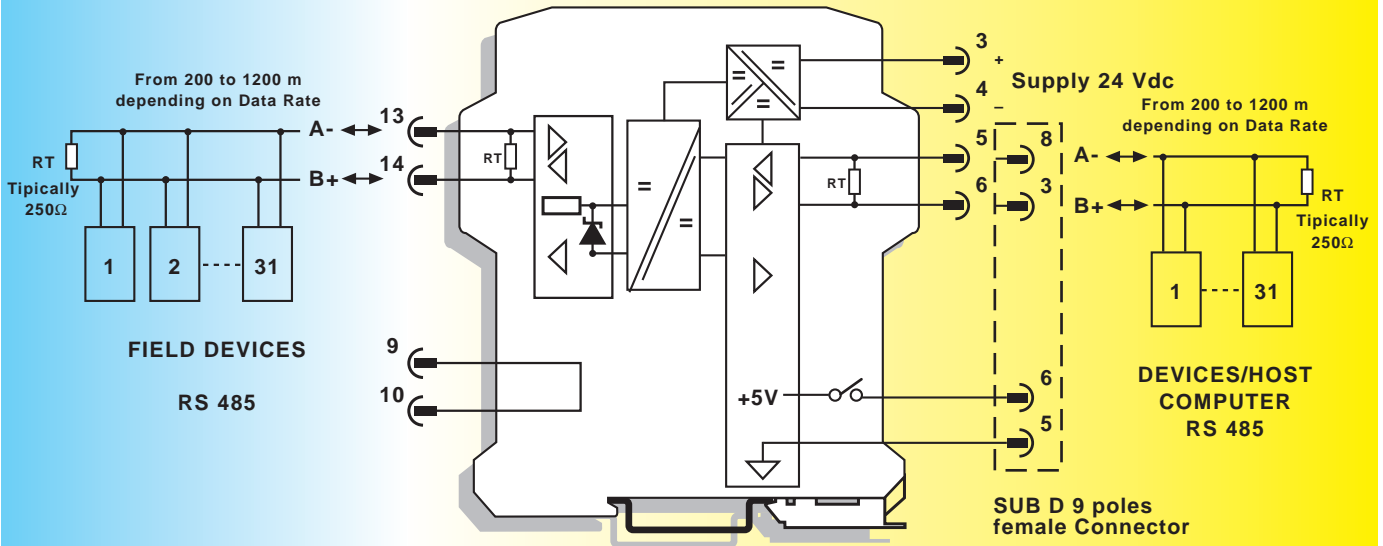

**Note:** Internal RT can be activated by Dip Switch.

**MODEL D1061S**

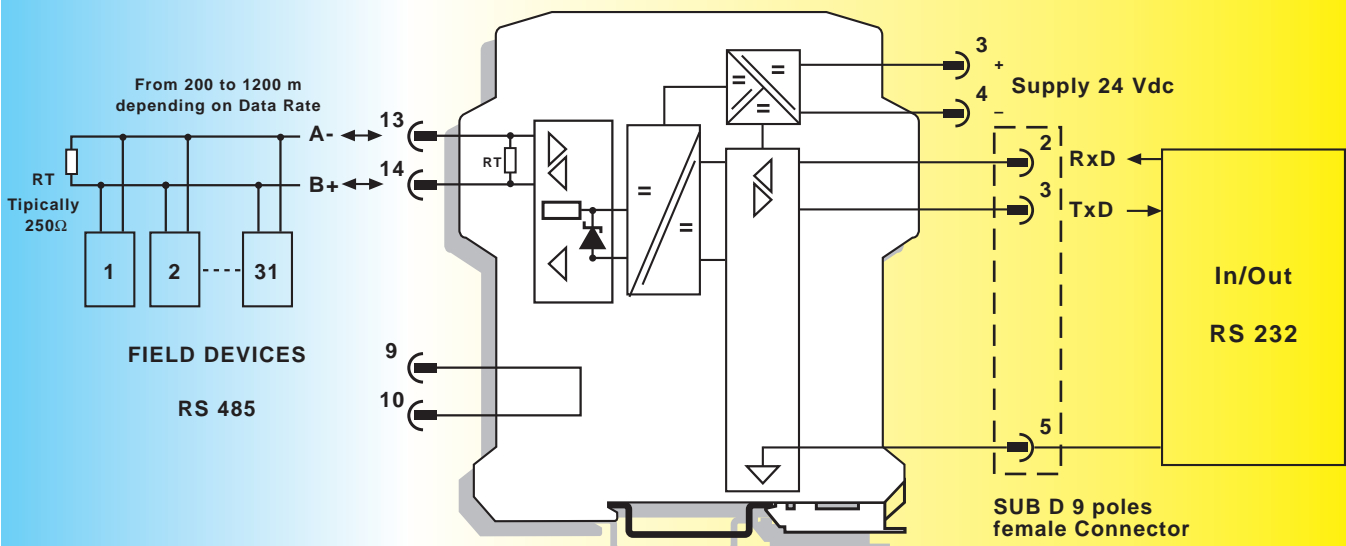

**Note:** Internal RT can be activated by Dip Switch.

# Function Diagram:

**HAZARDOUS AREA / HAZARDOUS LOCATIONS**  
**CLASS I, DIVISION 1, GROUPS A, B, C, D and**  
**CLASS II, DIVISION 1, GROUPS E, F, G or CLASS I, Zone 0, GROUP IIC**

**SAFE AREA / NON HAZARDOUS LOCATIONS or**  
**ZONE 2, GROUP IIC T4, CLASS I, DIVISION 2, GROUPS A, B, C, D T-Code T4,**  
**CLASS I, ZONE 2, GROUP IIC T4**

