

SIL 2 - SIL 3 Repeater Power Supply Smart-Hart Compatible DIN-Rail Models D1010S, D1010D

Characteristics:

General Description:

The single and dual channel DIN Rail Repeater Power Supply, D1010S and D1010D, provides a fully floating dc supply for energizing conventional 2-wire 4-20 mA Transmitter, or separately powered 3, 4 wire 4-20, 0-20 mA Transmitter located in Hazardous Area, and repeats the current in floating circuit to drive a Safe Area load.

The circuit allows bi-directional communication signals, for Smart Transmitters.

Function:

1 or 2 channels I.S. analog input for 2 wire loop powered or separately powered Smart Transmitters, provides 3 port isolation (input/output/supply) and current (source or sink) or voltage output signal.

Signaling LED:

Power supply indication (green).

Field Configurability:

mA (source or sink) or V output signal.

Smart Communication Frequency Band:

0.5 to 40 KHz within 3 dB (Hart and higher frequency protocols).

EMC:

Fully compliant with CE marking applicable requirements.

Front Panel and Features:

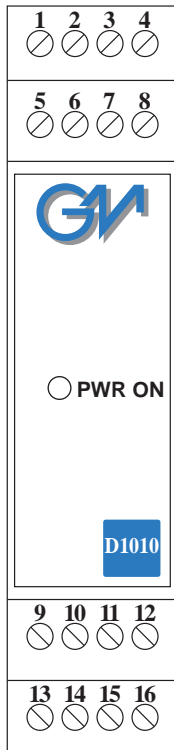

- SIL 2 according to IEC 61508, IEC 61511 for $T_{proof} = 5$ years.
- SIL 3 according to IEC 61508, IEC 61511 for $T_{proof} = 1$ year.
- 4-20 or 0-20 mA Input, Output Signal.
- Wide Band Smart Communication, Hart compatible.
- Input and Output short circuit proof.
- High Accuracy.
- Three port isolation, Input/Output/Supply.
- EMC Compatibility to EN61000-6-2, EN61000-6-4.
- Field programmability by DIP Switch.
- ATEX, UL & C-UL, Russia and Ukraine Certifications.
- DNV Type Approval Certificate No. A-10169 for marine applications.
- High Reliability, SMD components.
- High Density, two channels per unit.
- Simplified installation using standard DIN Rail plug-in terminal blocks.
- 250 Vrms (U_m) max. voltage applied to the instruments associated with barrier.

Ordering Information:

Model:	D1010		
1 channel		S	
2 channels		D	
Power Bus enclosure			/B

Technical Data:

Supply:

24 V nom (20 to 30 V) reverse polarity protected ripple within voltage limits ≤ 5 Vpp.

Current consumption @ 24 V: 115 mA for 2 channels D1010D, 60 mA for 1 channel D1010S with 20 mA output typical.

Max. power consumption: 3.70 W for 2 channels, 2.00 W for 1 channel with 30 V supply voltage and short circuit condition.

Isolation (Test Voltage):

I.S. In/Out 1.5 KV; I.S. In/Supply 1.5 KV; I.S. In/I.S. In 500 V; Out/Out 500 V; Out/Supply 500 V.

Input:

0/4 to 20 mA (separately powered input, voltage drop ≤ 1.0 V) or 4 to 20 mA (2 wire Tx current limited at ≈ 23 mA).

Transmitter line voltage:

≥ 15.0 V at 20 mA with max. 20 mVrms ripple on 0.5 to 40 KHz frequency band.

Output:

0/4 to 20 mA, on max. 600 Ω load in source mode; V min. 5 V at 0 Ω load V max. 30 V in sink mode, current limited at ≈ 23 mA or 0/1 to 5 V on internal 250 Ω shunt (or 0/2 to 10 V on internal 500 Ω shunt on request).

Response time: 50 ms (10 to 90 % step change).

Output ripple: ≤ 20 mVrms on 250 Ω communication load on 0.5 to 40 KHz band.

Frequency response: 0.5 to 40 KHz bidirectional within 3 dB (Hart and higher frequency protocols).

Performance:

Ref. Conditions 24 V supply, 250 Ω load, 23 ± 1 °C ambient temp.

Calibration accuracy: $\leq \pm 0.1$ % of full scale.

Linearity error: $\leq \pm 0.05$ % of full scale.

Supply voltage influence: $\leq \pm 0.05$ % of full scale for a min to max supply voltage change.

Load influence: $\leq \pm 0.05$ % of full scale for a 0 to 100 % load resistance change.

Temperature influence: $\leq \pm 0.01$ % on zero and span for a 1 °C change.

Compatibility:

CE CE mark compliant, conforms to 94/9/EC Atex Directive and to 89/336/CEE EMC Directive.

Environmental conditions:

Operating: Temperature limits -20 to + 60 °C,

relative humidity max 90 % non condensing, up to 35 °C.

Storage: Temperature limits - 40 to + 80 °C.

Safety Description:

II (1) G D [EEx ia] IIC or IM2 [EEx ia] I, II 3 G EEx nA IIC T4 associated electrical apparatus.

$U_0/V_{oc} = 27$ V, $I_0/I_{sc} = 93$ mA, $P_0/P_o = 625$ mW at terminals 14-15, 10-11.

$U_0/V_{oc} = 1.1$ V, $I_0/I_{sc} = 45$ mA, $P_0/P_o = 13$ mW at terminals 15-16, 11-12 (non energy storing apparatus connection).

$U_m = 250$ Vrms, -20 °C $\leq T_a \leq 60$ °C.

Approvals: DMT 01 ATEX E 042 X conforms to EN50014, EN50020, UL & C-UL E222308 conforms to UL913 (Div.1), UL 60079-0 (General, All Zones), UL60079-11 (Intrinsic Safety "i" Zones 0 & 1), UL60079-15 ("n" Zone 2), UL 1604 (Div.2) for UL and CSA-C22.2 No.157-92 (Div.1), CSA-E60079-0 (General, All Zones), CSA-E60079-11 (Intrinsic Safety "i" Zones 0 & 1), CSA-C22.2 No. 213-M1987 (Div. 2) and CSA-E60079-15 ("n" Zone 2) for C-UL, TCCEXEE (Russia) Nr.665 according to GOST R 51330.0-99, 51330.10-99 [Exia]IIC X, TCCEXEE (Ukraine) Nr.665 according to GOST 12.2.007.0, 22782.0, 22782.5 ExiallC X, Gosgortekhnadzor of Russia Permit Nr. PPC 04-11284. EXIDA Report No. GM03/07-24 R001, SIL 2 according to IEC 61508, IEC 61511. Please refer to Functional Safety Manual for SIL applications. DNV Type Approval Certificate No. A-10169 for marine applications.

Mounting:

T35 DIN Rail according to EN50022.

Weight: about 175 g D1010D, 125 g D1010S.

Connection: By polarized plug-in disconnect screw terminal blocks to accommodate terminations up to 2.5 mm².

Location: Safe Area/Non Hazardous Locations or Zone 2, Group IIC T4, Class I, Division 2, Groups A, B, C, D Temperature Code T4 and Class I, Zone 2, Group IIC, IIB, IIA T4 installation.

Protection class: IP 20.

Dimensions: Width 22.5 mm, Depth 99 mm, Height 114.5 mm.

Parameters Table:

Safety Description	Maximum External Parameters			
	Group Cenelec	Co/Ca (μF)	Lo/La (mH)	Lo/Ro (μH/Ω)
Terminals 14-15, 10-11				
Uo/Voc = 27 V	II C	0.089	4.2	56.5
Io/Isc = 93 mA	II B	0.705	15.0	226.1
Po/Po = 625 mW	II A	2.320	33.0	452.3
Terminals 15-16, 11-12	Non energy storing apparatus connection			
Uo/Voc = 1.1 V	II C			
Io/Isc = 45 mA	II B			
Po/Po = 13 mW	II A			

NOTE for USA and Canada:

II C equal to Gas Groups A, B, C, D, E, F and G.

II B equal to Gas Groups C, D, E, F and G.

II A equal to Gas Groups D, E, F and G.



Function Diagram:

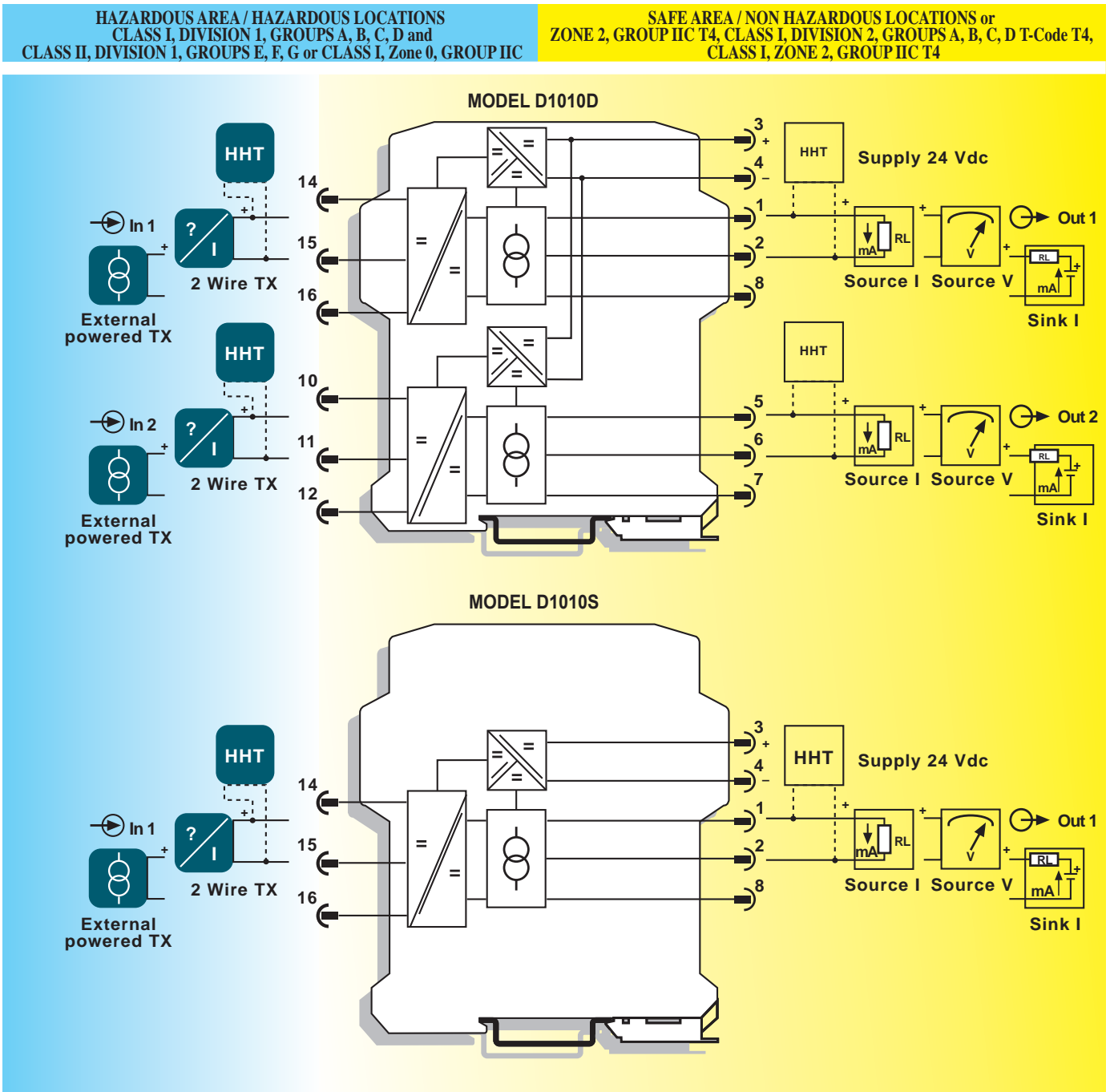

Function Diagram:

HAZARDOUS AREA / HAZARDOUS LOCATIONS
 CLASS I, DIVISION 1, GROUPS A, B, C, D and
 CLASS II, DIVISION 1, GROUPS E, F, G or CLASS I, Zone 0, GROUP IIC

SAFE AREA / NON HAZARDOUS LOCATIONS or
 ZONE 2, GROUP IIC T4, CLASS I, DIVISION 2, GROUPS A, B, C, D T-Code T4,
 CLASS I, ZONE 2, GROUP IIC T4

Safety Description

Terminals 14-15

$U_o/V_{oc} = 28.1\text{ V}$

$I_o/I_{sc} = 93\text{ mA}$

$P_o/P_o = 654\text{ mW}$

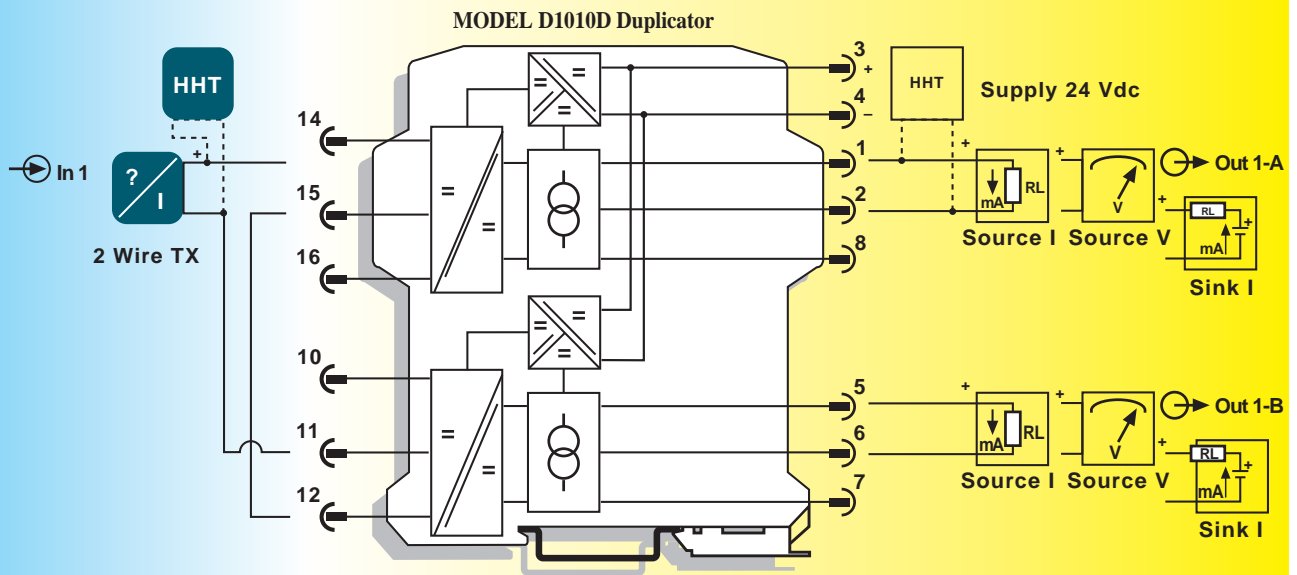

Connections for Duplication of 2 wire Transmitter Input.

Restriction on Specifications for 2 wire Transmitter Input.

- Bi-directional communication for Smart Transmitter is provided only output channel 1.
- The minimum supply voltage available for transmitters (V_{Tx}) is 14.0 V at 20 mA input.
- The allowable safety parameters must be changed in:
 - $U_o/V_{oc} = 28.1\text{ V}$.
 - $I_o/I_{sc} = 93\text{ mA}$.
 - $P_o/P_o = 654\text{ mW}$.

Function Diagram:

HAZARDOUS AREA / HAZARDOUS LOCATIONS
 CLASS I, DIVISION 1, GROUPS A, B, C, D and
 CLASS II, DIVISION 1, GROUPS E, F, G or CLASS I, Zone 0, GROUP IIC

SAFE AREA / NON HAZARDOUS LOCATIONS or
 ZONE 2, GROUP IIC T4, CLASS I, DIVISION 2, GROUPS A, B, C, D T-Code T4,
 CLASS I, ZONE 2, GROUP IIC T4

Safety Description

Terminals 15-16

$U_o/V_{oc} = 2.2\text{ V}$

$I_o/I_{sc} = 45\text{ mA}$

$P_o/P_o = 25\text{ mW}$

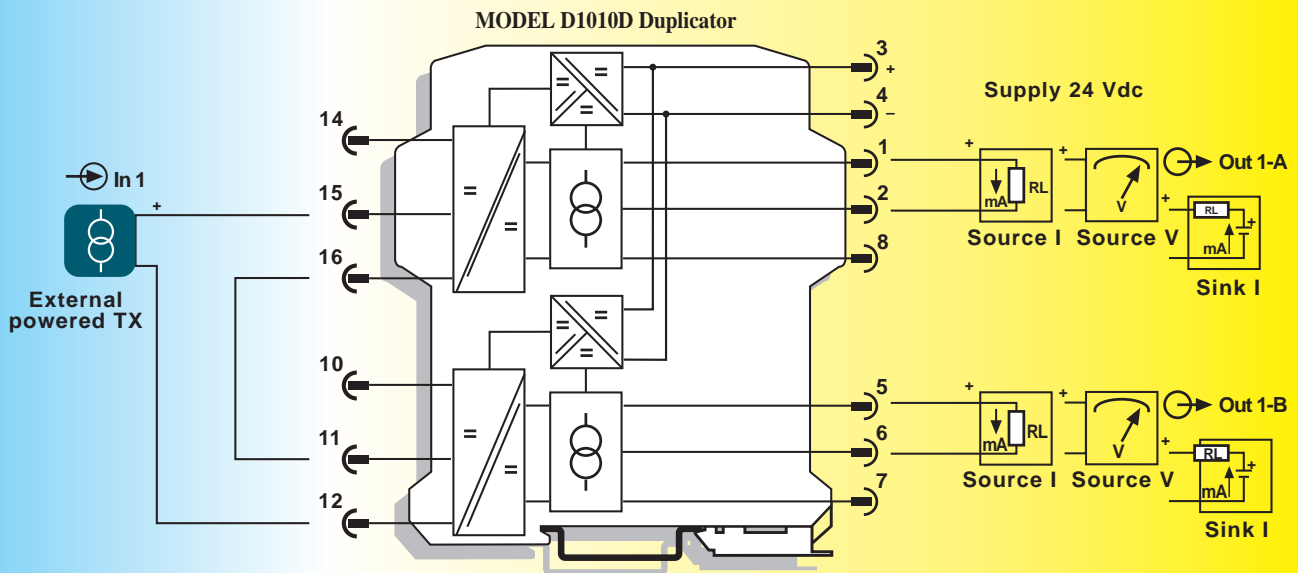

Connections for Duplication of Active Input Signals.

Restriction on Specifications for external powered Transmitter.

- The voltage drop must be changed in 2.0 V max.
- The allowable safety parameters must be changed in: $U_o/V_{oc} = 2.2\text{ V}$.
 $I_o/I_{sc} = 45\text{ mA}$.
 $P_o/P_o = 25\text{ mW}$.